



**PROCON  
ELECTRONICS**

# Magnetic Field Vehicle Detector

Model – MD102 PROBE & MD102C CONTROLLER

The **MD102 PROBE** is a magneto resistive sensor which is used to measure the earth's magnetic field. Any change in the magnetic field due to the presence of a vehicle will be detected resulting in a signal output.



The PROBE can measure the magnetic field in 3 axis, namely the X, Y and Z axis. Each axis can be individually enabled to optimize vehicle detection. Normally all 3 axis would be enabled.

The MD102 PROBE can be buried in the road surface underneath the vehicle, alongside the vehicle or can be mounted above the ground next to the passage of the vehicle.

The PROBE can be used to produce a pulse output or a presence out. The presence out will detect the vehicle indefinitely.

The **MD102C** is a control unit which enables configuration and testing of the MD102. DIP switches are used for configuration and LED's are used for visual indication of the operation of the PROBE. A relay output switches ON when a vehicle is detected.

The MD102 has been designed for parking and access control applications and is a cost effective solution for detecting vehicles in order to facilitate the automatic opening of security gates. It requires a minimal amount of cutting in the road surface.

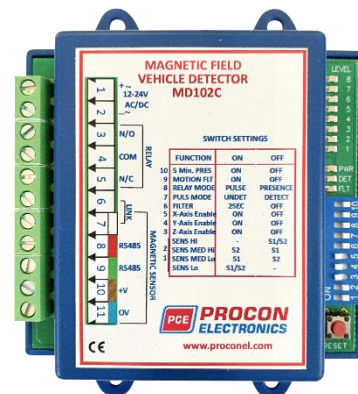

## Features

**Reset Switch.** Pressing the reset switch enables the MD102 PROBE to be manually reset during commissioning and testing. This results in the PROBE adjusting to the environment and becoming ready for vehicle detection. The switch settings are also used to update the PROBE. The PROBE stores these settings in non-volatile memory so that the MD102 PROBE can be used without the controller connected. The button must be pressed until the fault indicator comes ON.

**Switch selectable Sensitivity.** The detect sensitivity is the minimum change in magnetic field required to produce a detect output. Four sensitivity settings are available on the switches to allow flexibility in configuration.

**X, Y & Z Axis enable.** This feature enables the three axis. The output values from the axis are averaged to give a combined output. For normal use all of the axis should be enabled.

**Filter Option.** This option is used to provide a delay of 2 Seconds between detection of the vehicle and switching of the output relay. This delay is normally used to prevent false detection of small or fast moving objects.

**Relay Mode.** This switch configures the relay to operate in presence or pulse mode.

**Pulse Relay Selection.** The Pulse relay may be configured to energize on detection of a vehicle or to energize when the vehicle leaves the loop.

**Motion Filter.** This feature will only activate the presence relay output once the vehicle has stopped moving for at least 1 second.

**5 Minute Presence.** This feature will reset the detector after a 5 minute timeout.

## Indicators

**Power Indicator.** This LED Indicator illuminates when power is present.

**Detect Indicator.** This LED Indicator is illuminated when there is a vehicle present.

**Fault Indicator.** This LED Indicator is illuminated when there is a problem with the PROBE.

**Output Level Indicators.** There are 8 LED's which are used to show the amount that the magnetic field has changed. This is mainly used for the initial setup of the PROBE.

## Technical Specifications – MD102C Controller

<b>Power supply</b>	<b>MD102C</b> 12 - 24VAC/DC 50/60Hz 30mA
<b>Presence/Pulse Relay</b>	Change over contact 0.5A/220VAC
<b>Response time</b>	Approximately 100ms after vehicle enters PROBE area.
<b>Indicators</b>	LED indicators show: Power, Detect state and PROBE Fault.
<b>Connector</b>	11 Way Screw terminal block.
<b>Dimensions</b>	105mm X 90mm X 22mm
<b>Operating Temperature</b>	-20°C to +70°C
<b>Storage Temperature</b>	-40°C to +85°C

## Switch Settings – MD102C Controller

MD102C Switch Settings			
Switch No.	Function	ON	OFF
10	5 Minute Presence	On	Off
9	Motion Filter	On	Off
8	Relay Mode	Pulse	Presence
7	Pulse Mode	Undetect	Detect
6	Filter	2 Second	Off
5	X-Axis Enable	On	Off
4	Y-Axis Enable	On	Off
3	Z-Axis Enable	On	Off
1,2	Sensitivity High	-	S1/S2
1,2	Sensitivity Medium High	S2	S1
1,2	Sensitivity Medium Low	S1	S2
1,2	Sensitivity Low	S1/S2	-

## Wiring Connections – MD102C Controller

Screw Terminal	Description	PROBE Cable Details
1	Power Supply +V	
2	Power Supply 0V	
3	Relay Normally Closed N/O	
4	Relay Common COM	
5	Relay Normally Open N/C	
6	Link – PROBE Open collector	
7	Link – PROBE Open collector	
8	RS485	White
9	RS485	Red
10	PROBE Power +V	Green
11	PROBE Power 0V	Brown
		Blue

## Technical Specifications – MD102 PROBE

<b>Power supply</b>	<b>MD102</b> 12-24 VDC 10mA
<b>Presence/Pulse Output</b>	Open Collector transistor output.
<b>Response time</b>	Approximately 100ms after vehicle enters loop.
<b>Sensing Distance</b>	The probe should be placed less than 1.5m from the side of the vehicle or in the ground under the vehicle.
<b>Environmental tracking</b>	Automatic Compensation
<b>Cable</b>	Cable length 5m, 10m, 15m, 30m. 5 Core + Earth Screen
<b>Dimensions</b>	70mm X 20mm X 10mm
<b>IP Rating</b>	IP68
<b>Operating Temperature</b>	-20°C to +70°C
<b>Storage Temperature</b>	-40°C to +85°C

## Wiring Connections – MD102 PROBE

The MD102 PROBE can be used without the MD102C controller. The following table shows the colors of the wires. The RS485 would normally not be used in standalone mode.

Description	PROBE Cable Details
Earth Screen	Connect to earth at Controller End
PROBE Open collector (switches load to 0V)	White
RS485 - Not normally used.	Red
RS485 - Not normally used.	Green
PROBE Power +V	Brown
PROBE Power 0V	Blue

## Installation

The MD102 magnetic PROBE can be installed anywhere close to the travel of the vehicle. Best detection results are obtained when the PROBE is mounted underneath and as close to the vehicle as possible. The PROBE can be mounted in any orientation

1. Mounted on a pole alongside the passage of the vehicle.
2. Buried in the ground alongside the passage of the vehicle.
3. Buried in the road beneath the vehicle.

Whichever method is used, it is very important that the PROBE does not move during normal operation. Any movement will result in the PROBE giving a false detection output. If the PROBE is mounted in the ground beneath the vehicle, it is important to ensure that the tyres going over the PROBE do not put any downward pressure on the PROBE because this will result in movement of the PROBE and a false detection. When the slot above the PROBE is filled in, ensure that the fill material is concave so that it does not come into contact with the tyre of the vehicle.

The cable is designed for direct burial, however it is recommended that it is placed in a conduit for extra protection. The cable can be cut shorter if the MD102C controller is installed close to the PROBE.

## Diagnostics

SYMPTOM	POSSIBLE CAUSE	SOLUTION
The POWER LED is not on.	No power supply voltage on the input.	Check that the power supply is correctly wired to the controller. (Terminals 1 and 2)
The FAULT LED stays On.	There may be a poor connection in the wiring to the PROBE.	Check all wiring. Tighten screw terminals. Check for broken wires.
The DETECT LED stays on.	Local environmental change.	Re-calibrate the PROBE by pressing the reset button.

## Order Codes

Order Code	Description
MD102C	MD102 Controller Unit
MD102-5	MD102 Magnetic PROBE – 5m Cable
MD102-10	MD102 Magnetic PROBE – 10m Cable
MD102-15	MD102 Magnetic PROBE – 15m Cable
MD102-30	MD102 Magnetic PROBE – 30m Cable

## Contact Details



Refer to our web site for distributor details.

Email: [proconel@proconel.com](mailto:proconel@proconel.com)

Web: [www.proconel.com](http://www.proconel.com)